

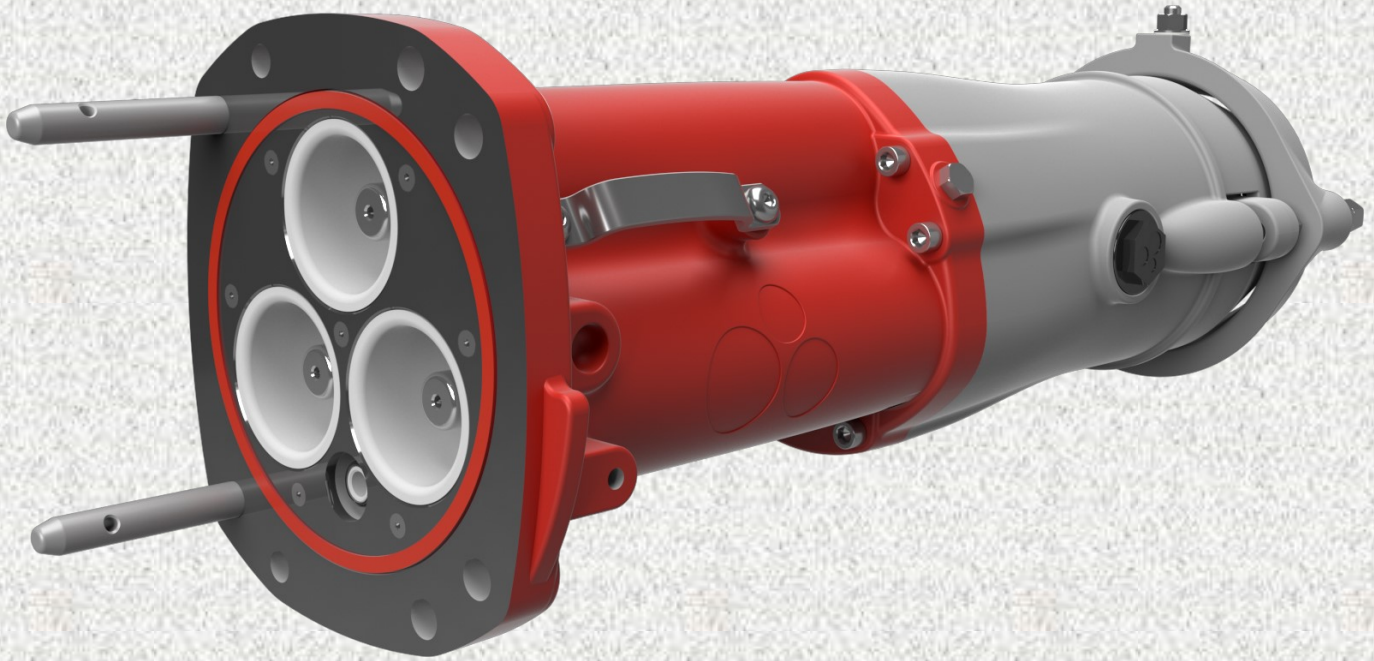

11kV 800 AMP 4 Bolt KA Style Coupler

114BKA - Range



Pioneering the Difference.

The AusProof high voltage coupler and adaptor system demonstrates state of the art technology with an innovative design which becomes homogeneous with the cable when terminated. The design offers a continued earth shield, segregating the three phases and maintains the same Symmetrical radial distribution of voltage stress, as in the cable design. This eliminates the risk of a phase to phase fault.

The face profile and silicon rubber connector expels all air when connected, eliminating condensation, dust and corona. The type tests performed were all based on high voltage, cable specification requirements, and the results prove; that the coupler is as good as the cable.

Electrical Type Test Results

11kV 800A Coupler

Through Fault Current

20kA for 0.3 Seconds
20kA for 0.3 Seconds
20kA for 1.0 Seconds
At 10 Minutes Intervals

Impulse Voltage

95kV - 10 POS and 10 NEG
110kV - 10 POS and 10 NEG

A/C High Voltage Withstand

24kV for 1 Minute
50kV for 1 Minute
35kV for 6 Hours

Partial Discharge

Prior to 6 Hour:
High Voltage Withstand: 10pC
Post 6 Hour:
High Voltage Withstand: 0.6pC

High Voltage Cable Coupler System

Technical Guide

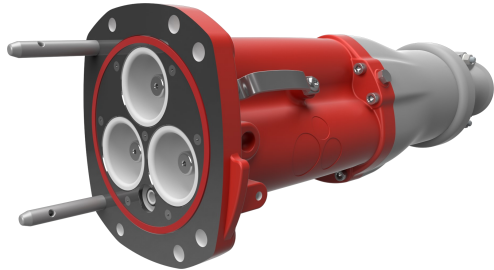

Stock No: (See Page 4 Breakdown)
Description: Half Coupler for Trailing Cable
Rating: 11kV 800A
Material: Aluminium
LOA: 665mm
Mass: 16kg
Volume: 4 litres



Stock No: (See Page 4 Breakdown)
Description: Half Coupler for Armoured Cable
Rating: 11kV 800A
Material: Aluminium
LOA: 665mm
Mass: 16kg
Volume: 4 litres

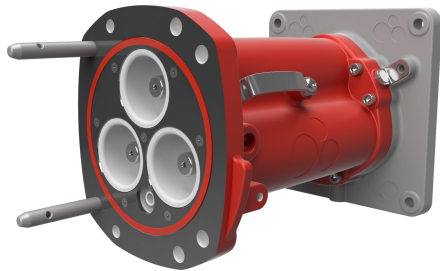

Stock No: (See Page 4 Breakdown)
Description: KA Adaptor
Rating: 11kV Adaptor
Material: Aluminium
LOA: 480mm
Mass: 16kg
Volume: 4 litres

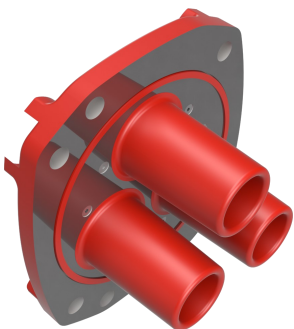

Stock No: RS2131
Description: Insulated End Cover
Rating: 11kV
Material: Aluminium
Mass: 5kg



Stock No: 2852
Description: Cast Protection Cover No Handle/Boss



Stock No: RS2130
Description: Cast Protection Cover
Rating: 11kV
Material: Aluminium
Mass: 3kg



Stock No: RS112 (3 required per joint)
Description: Phase Connectors
Rating: 11kV 800A



Stock No: RS117
Description: Earth Pilot Connector

High Voltage Cable Coupler System

Model No Selection Guide - 11kV 800A

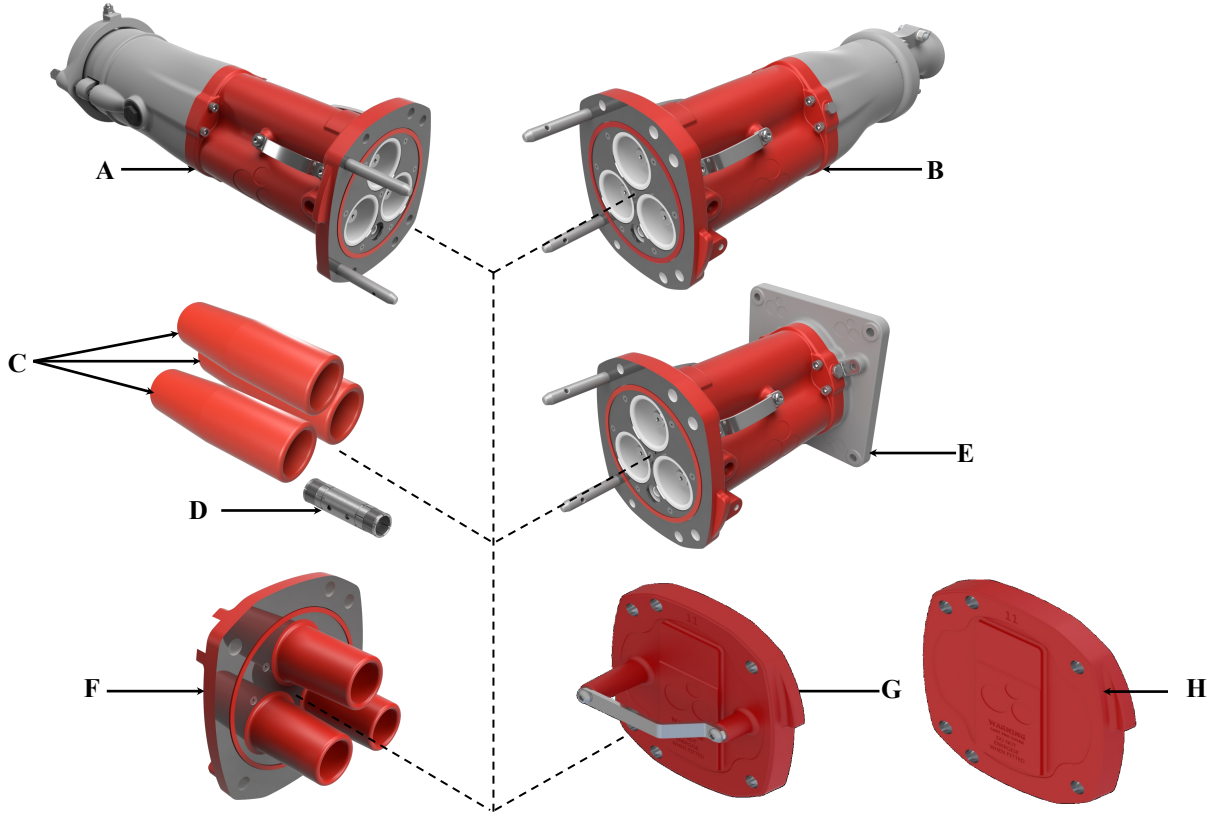

	Description	Stock No.	Page
A	Half Coupler - Armoured Cable	-	4
B	Half Coupler - Unarmoured Cable	-	4
C	800x800 Phase Connectors	RS112	2
D	Earth Pilot Connector	RS117	2
E	Adaptor	RS1773	8
F	Insulated End Cover	RS2131	9
G	Cast Protection Cover	RS2130	10
H	Cast Protection No Handle	2852	10

High Voltage Cable Coupler System

Stock Selection Guide - 11kV 800A

Gear Mount Flange
Stock No: RS1773

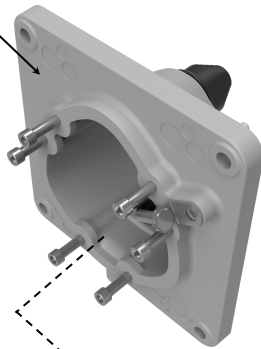

Coupler
Stock No: RS1357

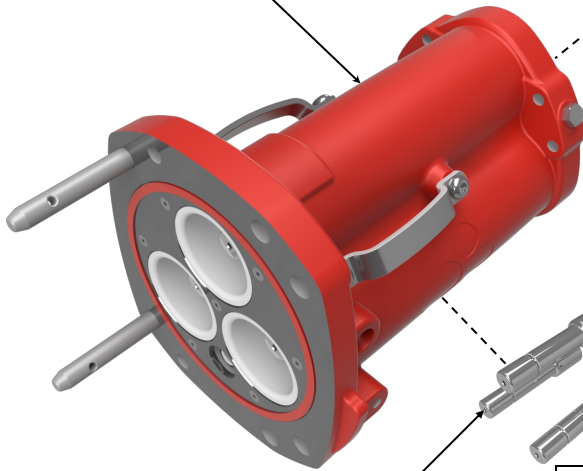

Soldered Contact (Set of 3)	
Conductor	Stock No
35mm sq	RS067
50mm sq	RS068
70mm sq	RS069
95mm sq	RS070
120mm sq	RS071
150mm sq	RS072
185mm sq	RS073
240mm sq	RS074
300mm sq	RS075

Crimpable Contact (Set of 3)	
Conductor	Stock No
25mm sq	RS866
35mm sq	RS076
50mm sq	RS077
70mm sq	RS078
95mm sq	RS079
120mm sq	RS080
150mm sq	RS081
185mm sq	RS082
240mm sq	RS083
300mm sq	RS084

KAN SWA Cable Gland			
Cable OD Under Armour	Stock No	Cable OD Under Armour	Stock No
105 - 110mm	RS1343	70 - 75mm	RS1350
100 - 105mm	RS1344	65 - 70mm	RS1351
95 - 100mm	RS1345	60 - 65mm	RS1352
90 - 95mm	RS1346	55 - 60mm	RS1353
85 - 90mm	RS1347	50 - 55mm	RS1354
80 - 85mm	RS1348	45 - 50mm	RS1323
75 - 80mm	RS1349	40 - 45mm	RS1355

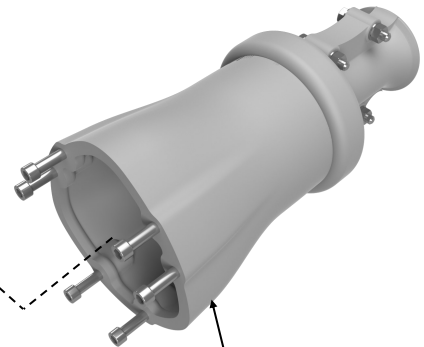
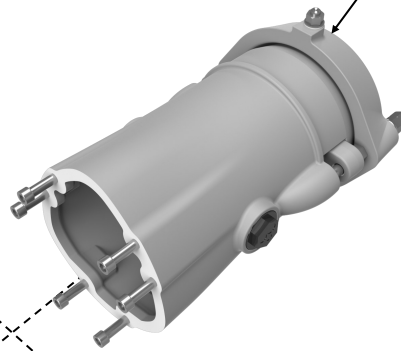

KA Trailing Cable Gland			
Cable OD	Stock No	Cable OD	Stock No
117mm sq	RS1867	80mm	RS1875
115mm sq	RS1868	75mm	RS1876
110mm sq	RS1869	70mm	RS1877
105mm sq	RS1870	65mm	RS1878
100mm sq	RS1871	60mm	RS1879
95mm sq	RS1872	55mm	RS1880
90mm sq	RS1873	50mm	RS1881
85mm sq	RS1874	45mm	RS1882

High Voltage Cable Coupler System

Body Assembly

Stock No: RS1357 - 11kV KA 4 Bolt Body

Amps: 800

Volume: 4 Litres

Volts: 11000

LOA: 840mm

Material: Aluminium

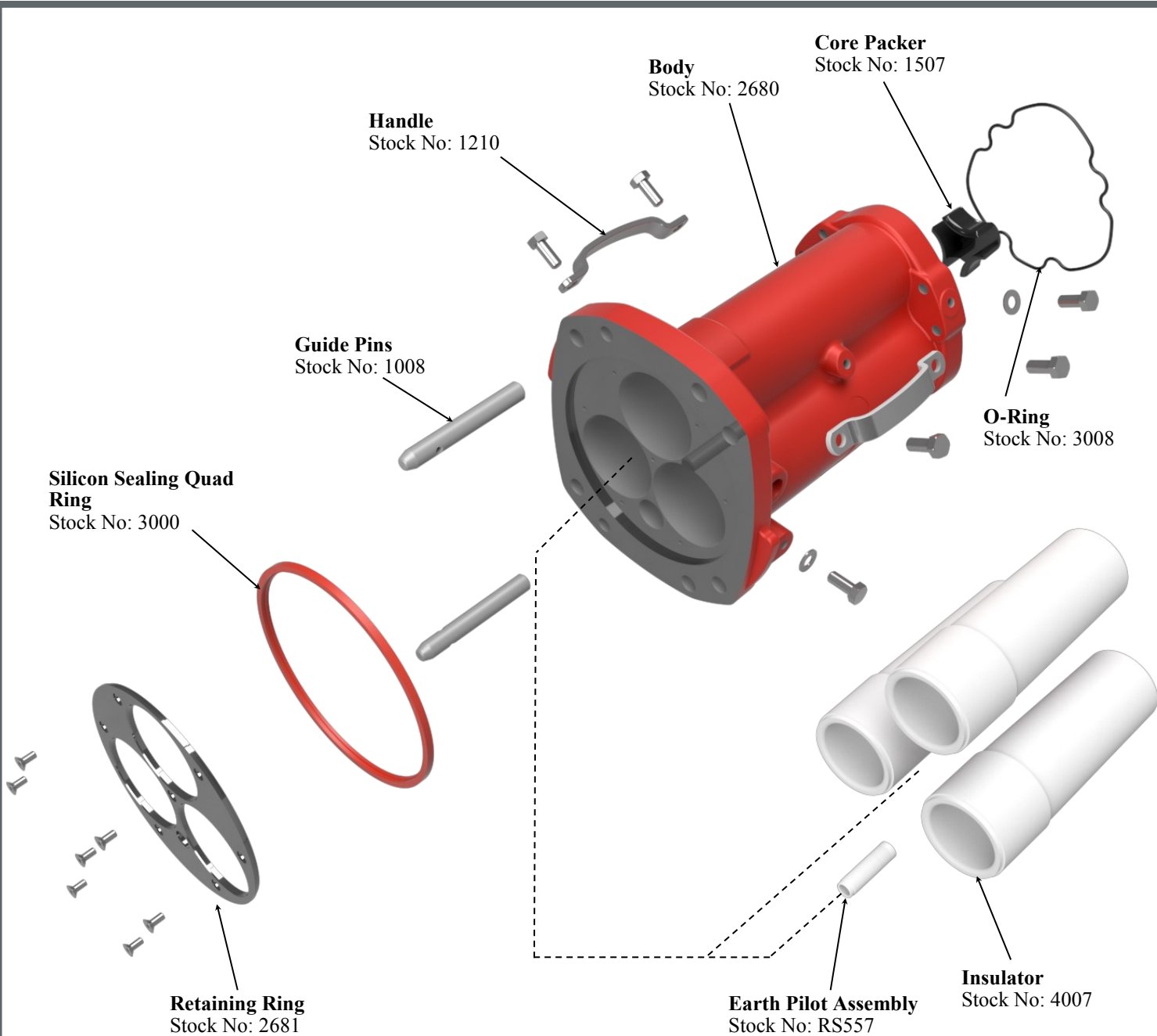

High Voltage Cable Coupler System

Unarmoured Gland Assembly

KA Housing Small
Stock No: RS257

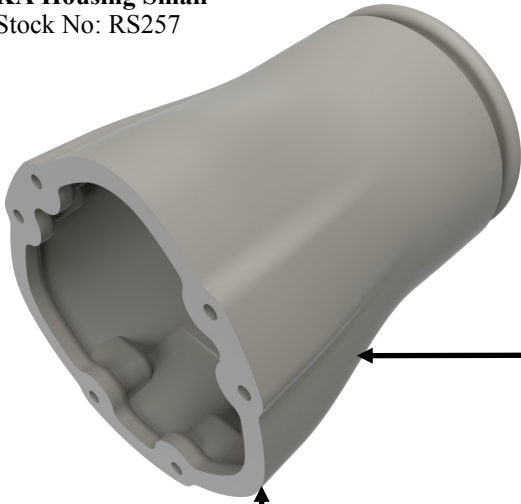

KA Housing Large
Stock No: RS258

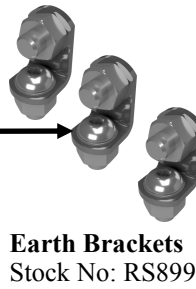
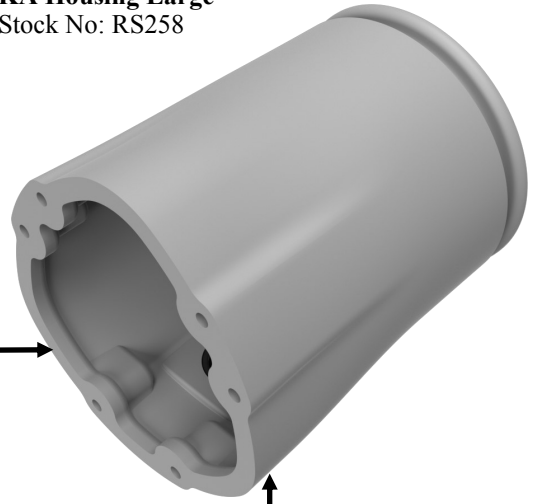

Alum Unarmoured Compression Clamp Kit

Cable OD	Stock No
90mm	RS266
85mm	RS265
80mm	RS264
75mm	RS263
70mm	RS262
65mm	RS261
60mm	RS260
55mm	RS259
50mm	RS478
45mm	RS479

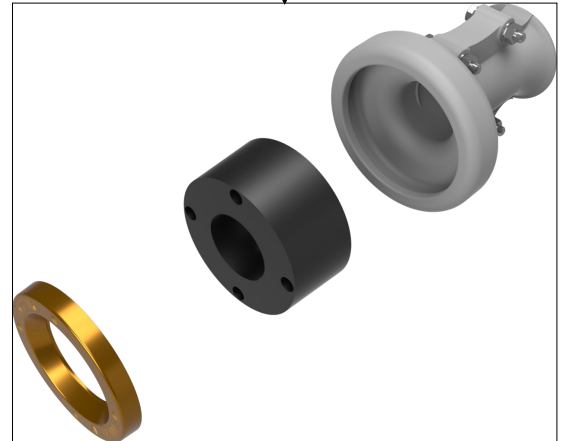

Alum Unarmoured Compression Clamp Kit

Cable OD	Stock No
95mm	RS267
100mm	RS268
105mm	RS269
110mm	RS270
115mm	RS271
117mm	RS272
125mm	RS916

High Voltage Cable Coupler System

Armoured Gland Assembly



KANS—Small Housing
Stock No: RS1342

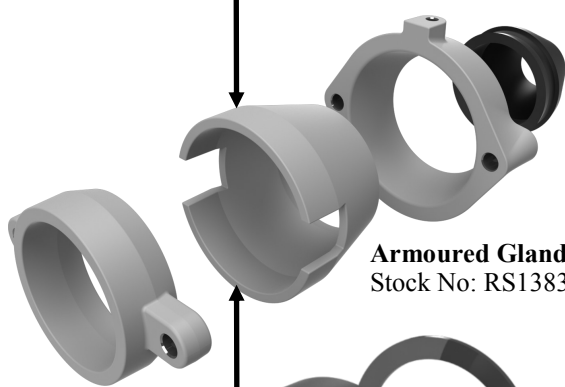

Armoured Gland Kit
Stock No: RS1383

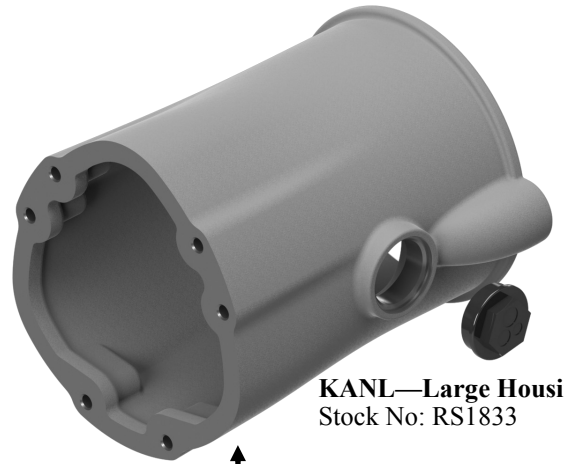
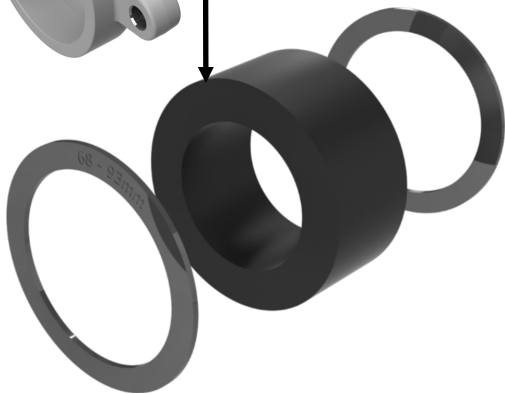

KANL—Large Housing
Stock No: RS1833

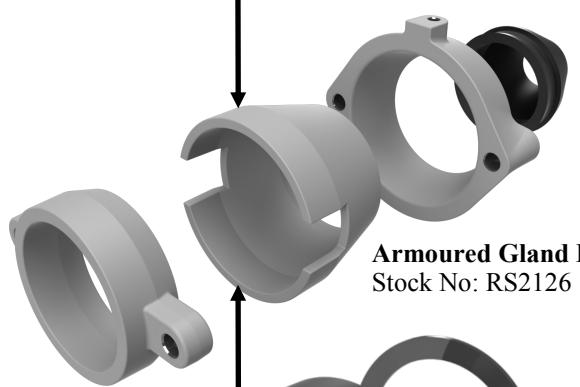

Armoured Gland Kit
Stock No: RS2126

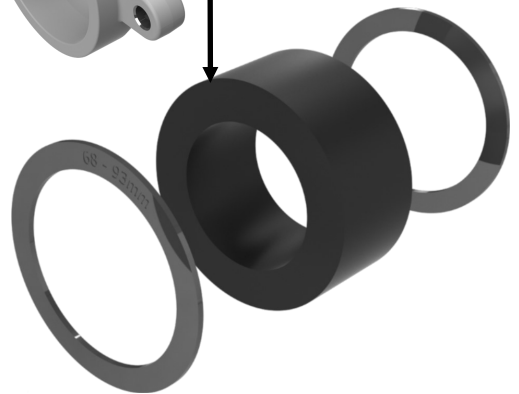

Panel Mount Adaptor Body Assembly

To Fit to New Switch Gear Stations

Stock No: RS1773 - 11kV KA Adaptor Flange

Mass: -

Volts: 11000

Material: Aluminium

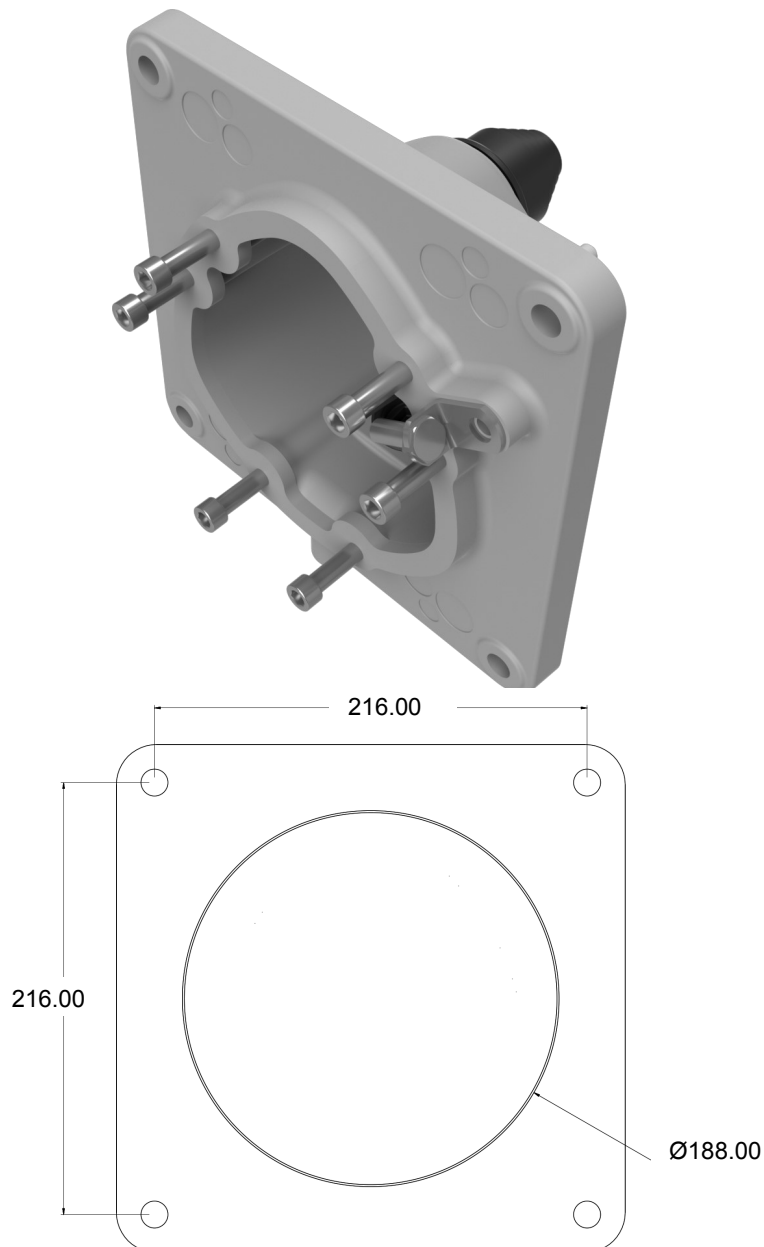

Insulated End Cover Assembly

Accessories

Stock No: RS2131—11kV KA 4B Insul. End Cover

Mass: -

Volts: 11000

Material: Aluminium

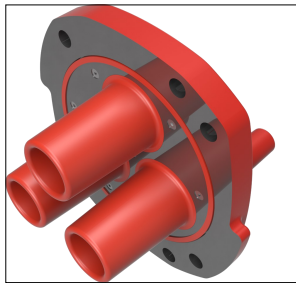

End Cover
Part No: 2554

End Cover Plug
Part No: 3001

Sealing Ring
Part No: 3000

Retaining Ring
Part No: 2681

Stock No: 2555 — 11kV KA 4B Cast Pro Cover

Mass: -

Volts: 11000

Material: Aluminium



Cast Pro Cover
Part No: RS2130



Cast Pro Cover No Handle
Part No: 2852

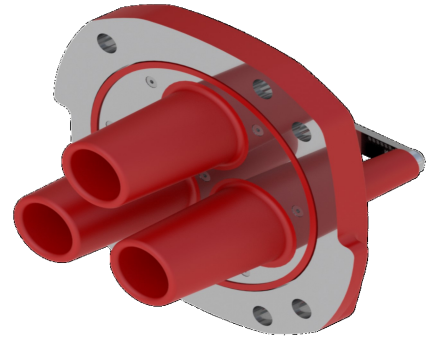

Insul. End Cover
Part No: RS2131

RS178

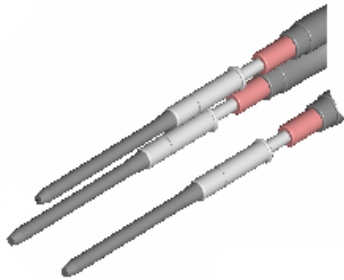

Phase Guide Stick Set for Assembly
3 Included

RS177



Slide Hammer

Coupler Tool Kit (All Voltages)

Part No. RS284



1246 (Spanners) x 2

RS325 (Coupling Tool) x 1





RS177 (Slide Hammer) x 1

1278 (High Voltage Cleaning tissues) x 15





1274 (Tool Box) x 1

Termination Kits for Unarmoured Cable

11kV Termination Kit Large 24mm-48mm

RS323	
(To suit core outer diameter 24mm-48mm)	
	4L Compound
	3 x QT5672
	1 x CC2
	1 x I3 Tape

11kV Termination Kit Small 16mm-28.5mm

RS406	
(To suit core outer diameter 16mm-28.5mm)	
	4L Compound
	3 x QT5672
	1 x CC2
	1 x I3 Tape

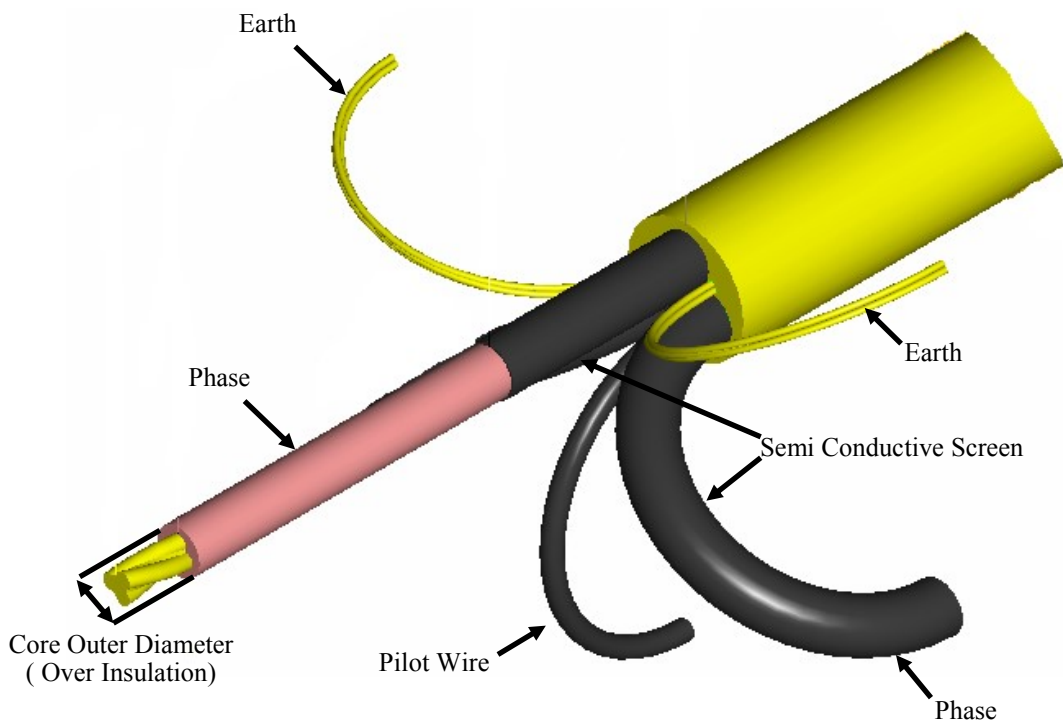

Termination Kits for Armoured Cable

11kV SWA Termination Kit Large 24mm-48mm

RS552	
(To suit core outer diameter 24mm-48mm)	
	4L Compound
	QT5672 x 3
	CC2 x 1
	I3 Tape x 1
	Heat Shrink x 1
	Steel Cable Ties x 2

11kV SWA Termination Kit Small 16mm-28.5mm

RS551	
(To suit core outer diameter 16mm-28.5mm)	
	4L Compound
	QT5671 x 3
	CC2 x 1
	I3 Tape x 1
	Heat Shrink x 1
	Steel Cable Ties x 2

11kV SWA Termination Kit Extra Small 11mm-17mm

RS917	
(To suit core outer diameter 11mm-17mm)	
	4L Compound
	QT5662 x 3
	CC2 x 1
	I3 Tape x 1
	Heat Shrink x 1
	Steel Cable Ties x 2

11kV Termination Kit PILC 24mm-48mm

RS687	
	4L Compound
	23 Tape x 2
	Heat Shrink x 1
	Steel Cable Ties x 2

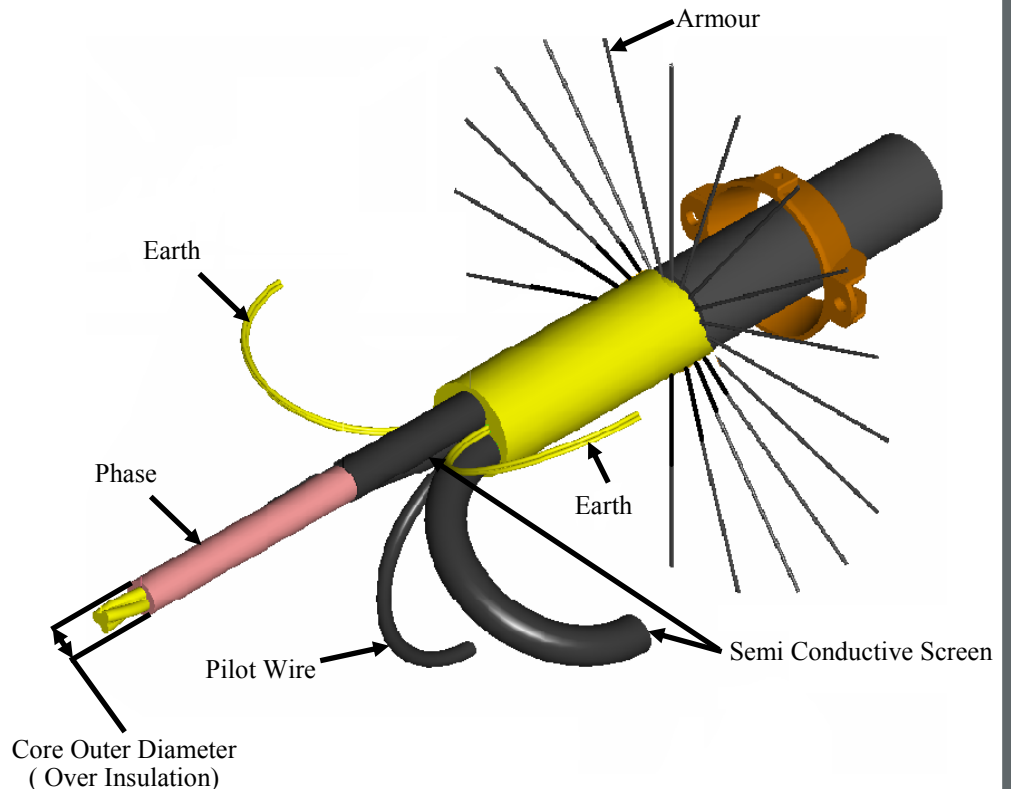

Open Cut Bolted Coupler Skid for 11kV

Stock No: RS186 - 11kV 4 Bolt Standard Skid

Mass: -

Volts: 11000

Material: Aluminium

Cable Clamp	
ID Sizes	Stock No
120mm	RS326
115mm	RS327
110mm	RS328
105mm	RS329
100mm	RS330
95mm	RS331
90mm	RS332
85mm	RS333
80mm	RS334
75mm	RS335
70mm	RS336
65mm	RS337
60mm	RS338
55mm	RS339
50mm	RS480
45mm	RS481

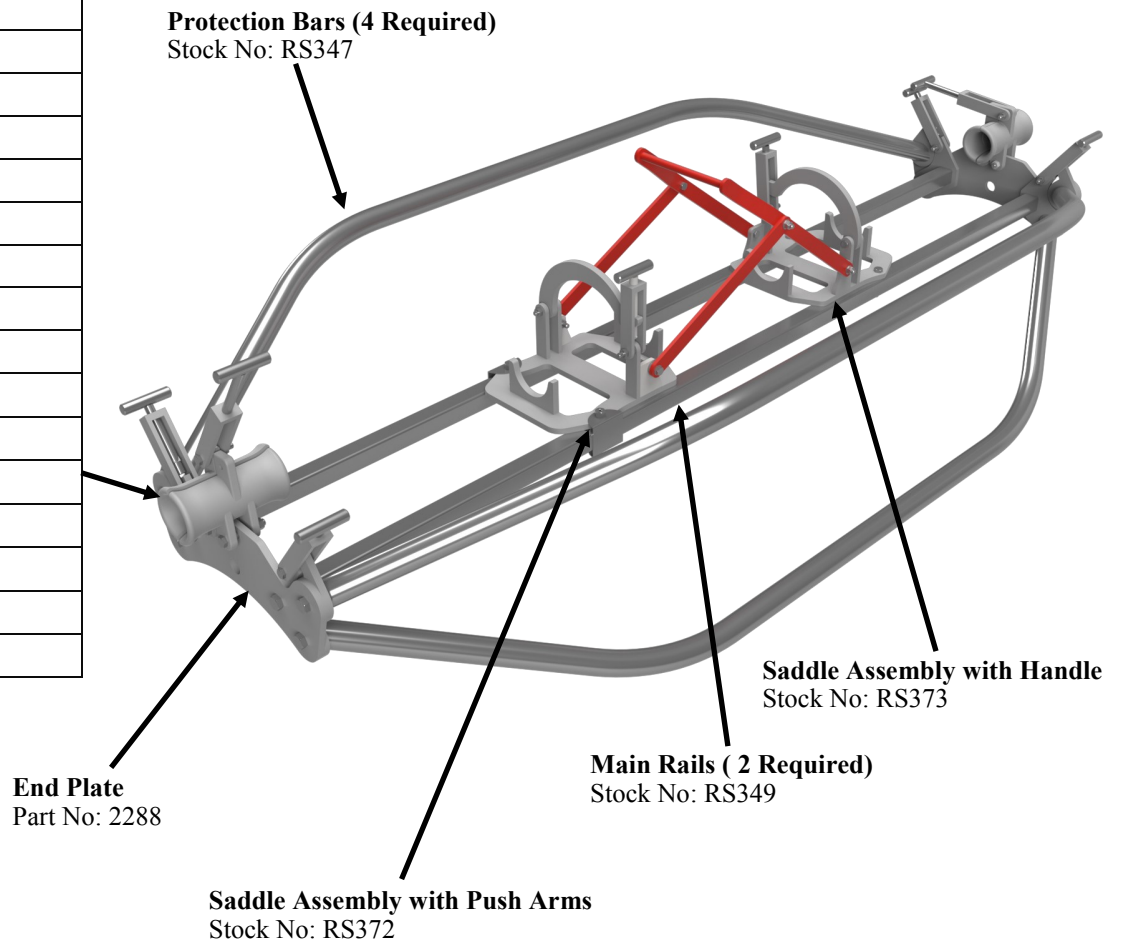

KA 11kV 800A Unarmoured

Termination Procedure

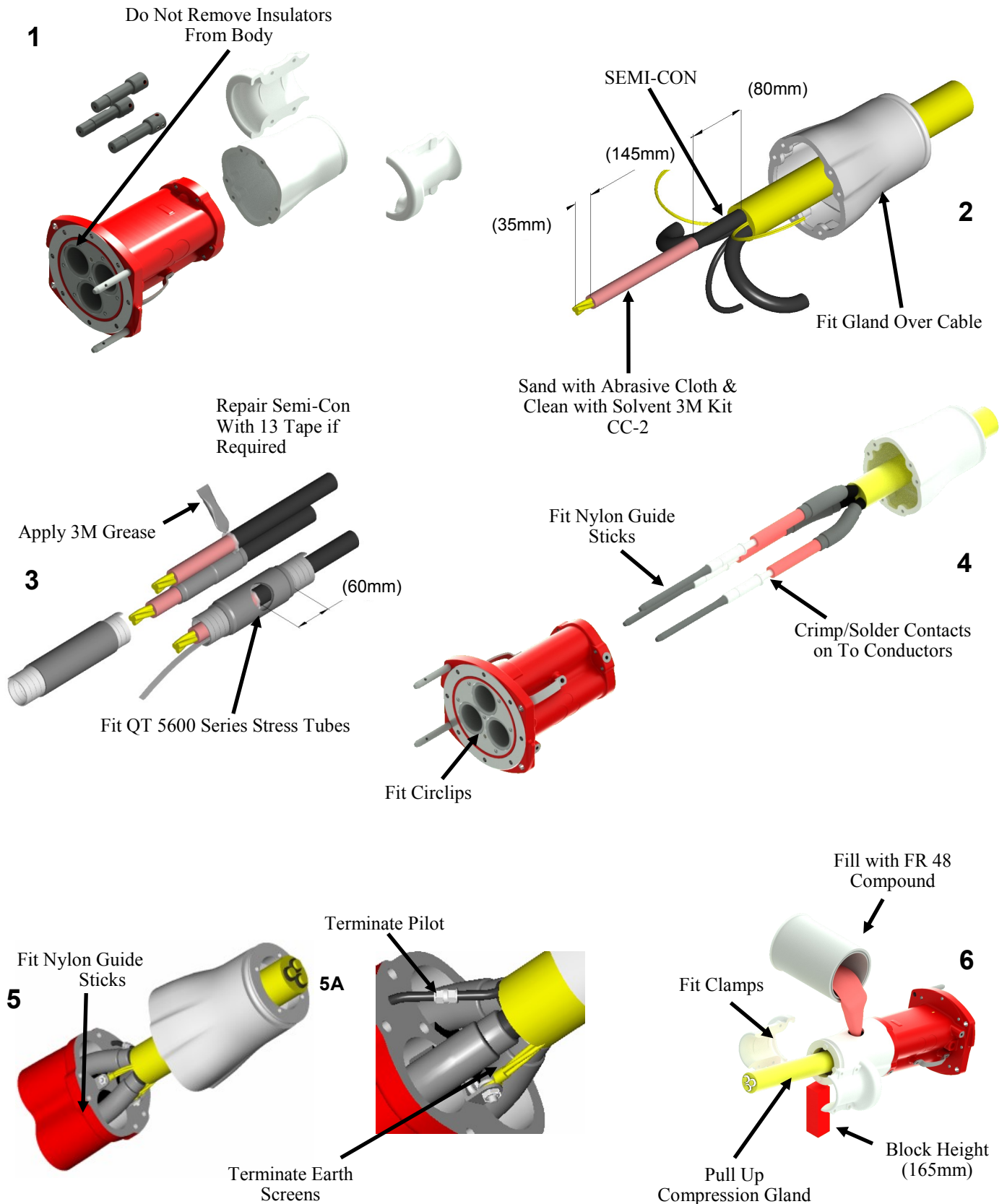

KA 11kV 800A Gear Mount Adaptor

Termination Procedure

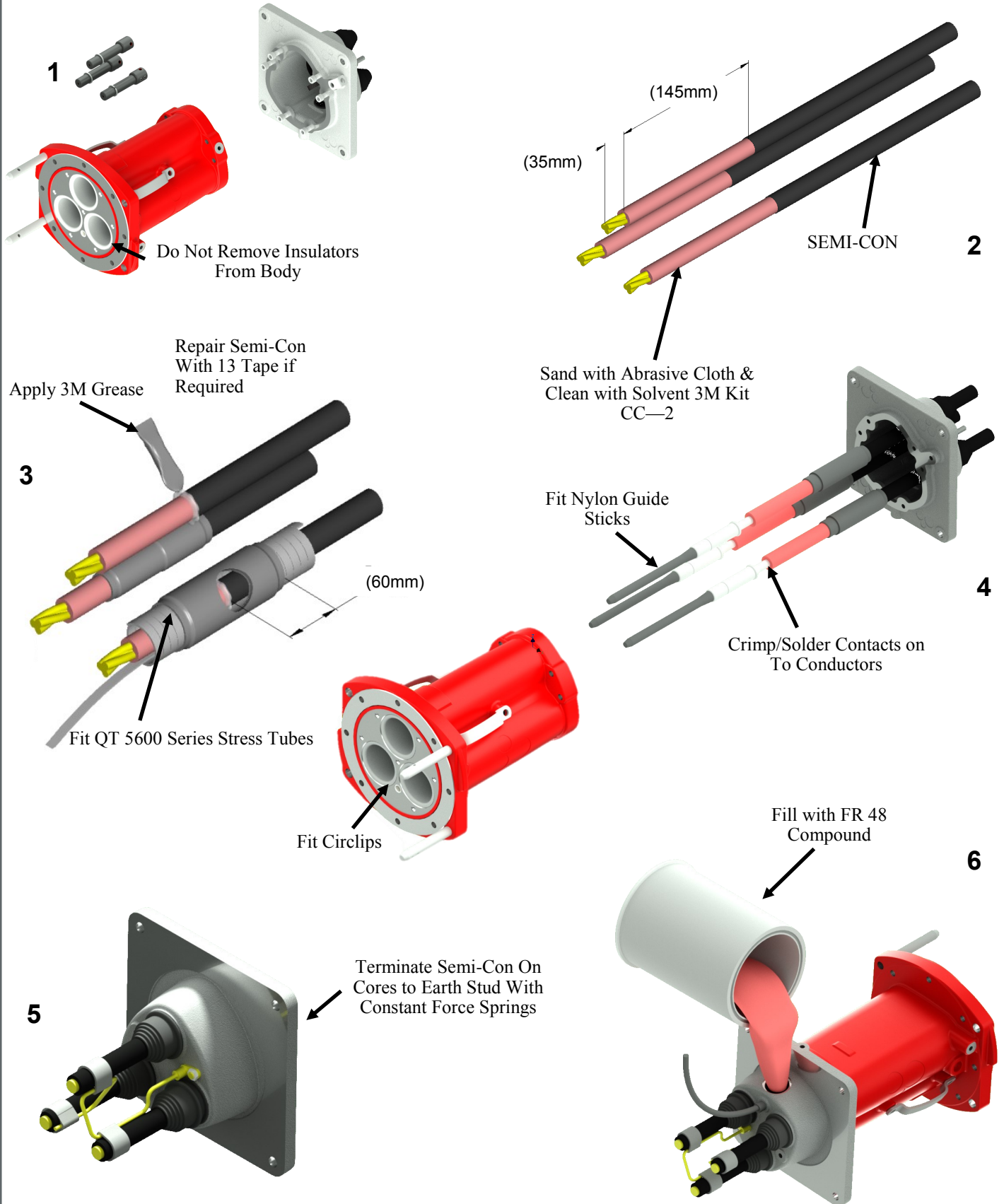

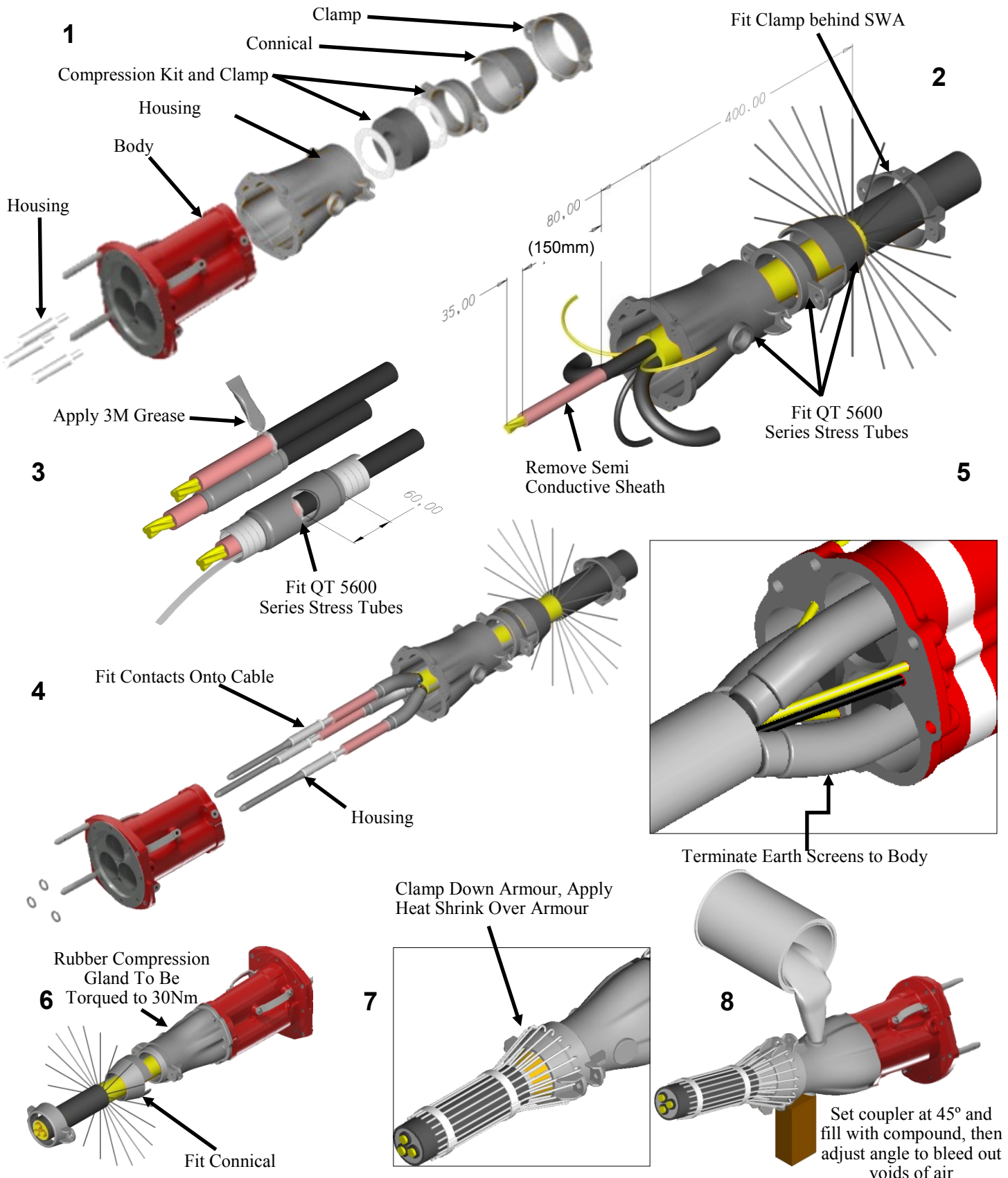

Contact Pulling Tool Operation

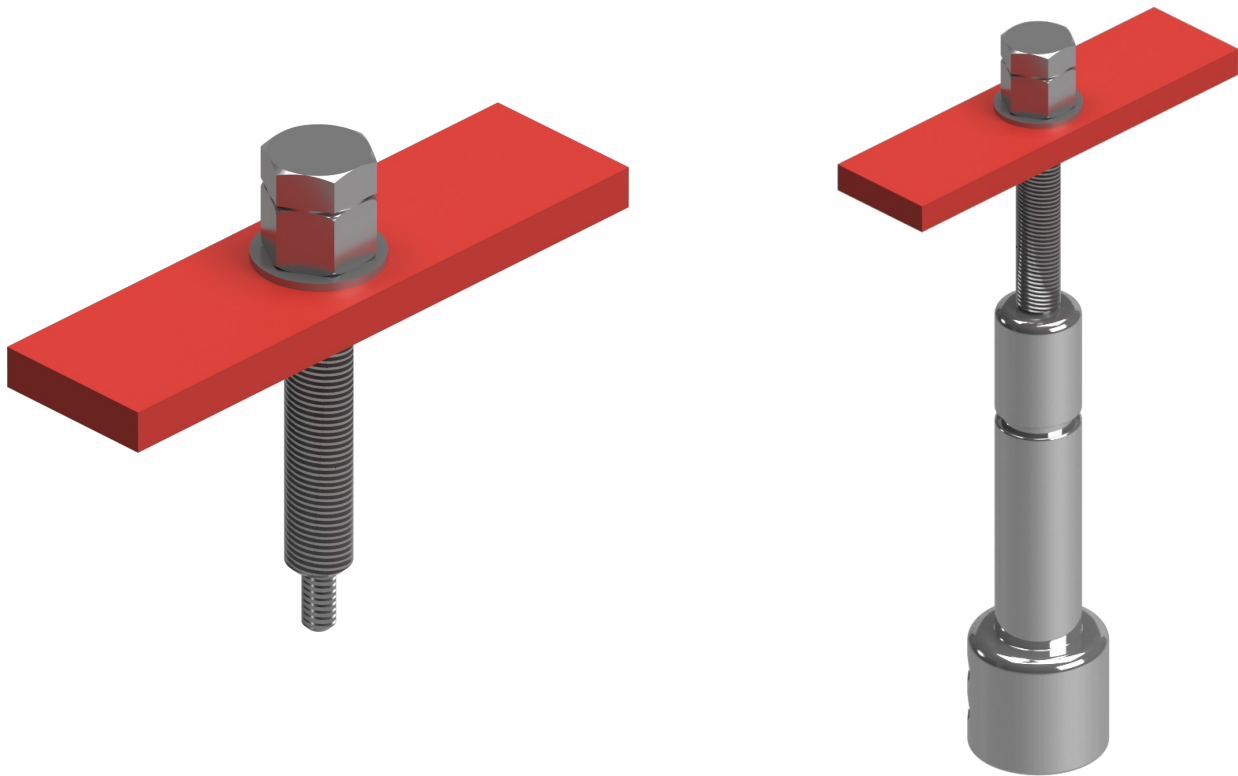

Observation

Inspect the front end of the coupler or adaptor, paying special note to the condition of the circlip on each phase. Each circlip should be sitting evenly on the contact. If more of the circlip protrudes out of one side, then the circlip needs to be replaced.

If the circlip needs to be adjusted or replaced, the following will need to be performed

- Ensure power is not connected.
- For a coupler, loosen the clamp on the gland to slightly release the grip on the cable.
- Clean out threaded hole in end of contact with air or cloth
- Place a new circlip over the end of the contact.
- Screw the bolt of the assembled pulling tool into the end of the contact
- Push the steel plate up against the face of the coupler.
- Tighten the nut and washer up to the steel plate.
- Using a spanner, tighten the nut against the steel plate to pull the contact back into place.
- Whilst in this position, replace the circlip.
- After all three contacts are satisfactory, retighten the gland.

Inserting Connectors and Coupling Operation

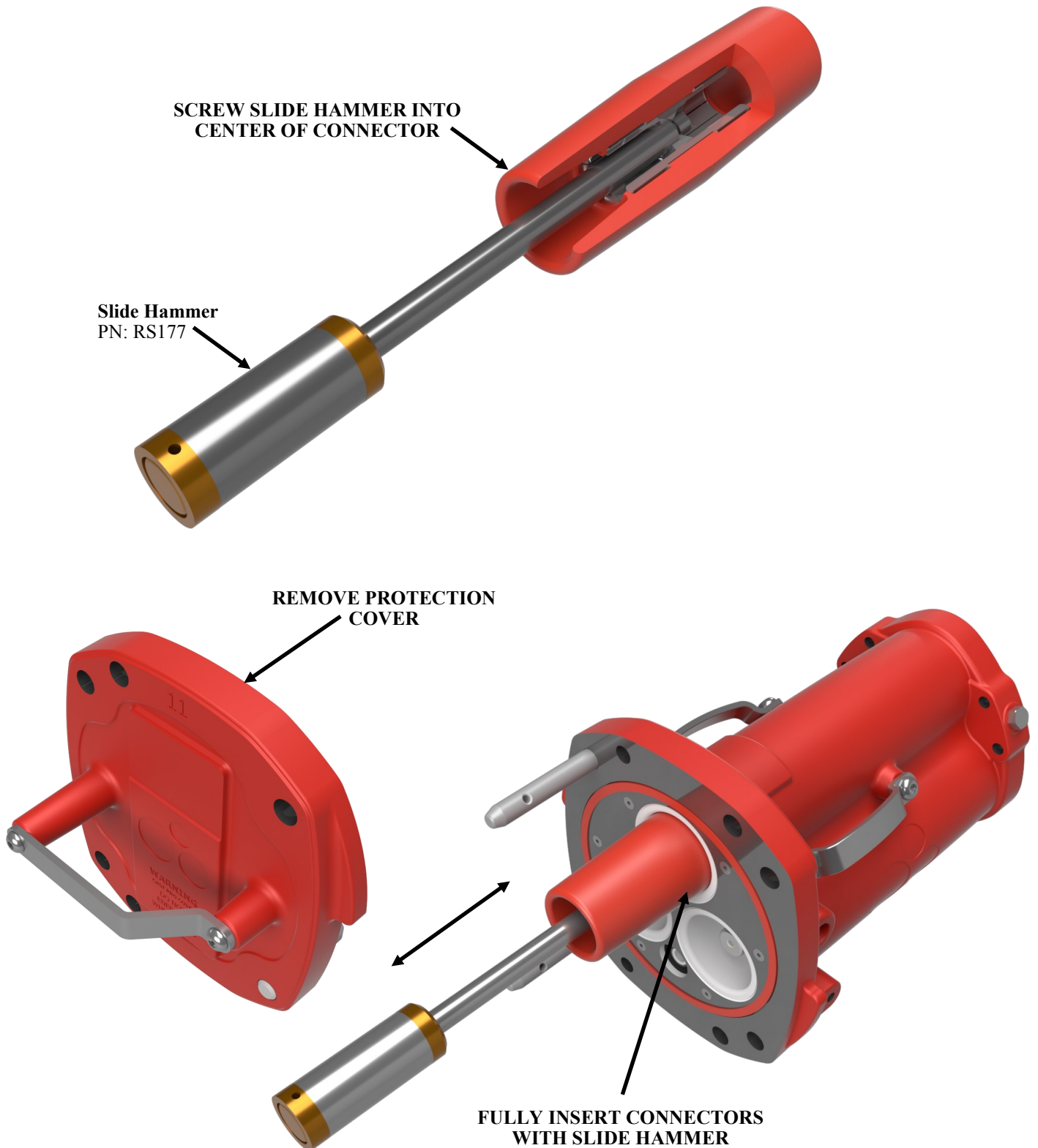

Offsite Checks & Testing Procedures

For 11kV Aluminium Coupler System

To compliment existing procedures and practices currently existing in cable repair workshop, the following is designed to be completed as a minimum to ensure the safe and long operation of the AusProof coupler system

Routine Checks and Inspection

- When cables are not in use or stored, ensure that a cast protection end cover is fitted that provides adequate sealing against moisture.
- Ensure that witness marks are brightly painted on the sheath, located where the cable enters the gland. This needs to be routinely inspected to check if a gap appears between the end of the gland and the witness mark.
 - A gap may indicate that the cable has been under tension and that the termination in the coupler may have moved.
- Inspect the male pin in the coupler for obvious signs of damage. Also inspect the location of the nylon locking circlip to ensure that it is evenly fitted onto the contact.
 - If the circlip appears dislocated or damaged then repairs are necessary. This event indicates that the termination in the coupler has been under tension as a result of handling.
- Ensure the tension on the gland housing compression ring is maintained. This process requires that the four compression ring bolts are tensioned.
- Check silicon seals are clean and are fully intact.
- Thoroughly clean the insulators and face of the coupler with suitably approved solvent.



6 Shona Avenue

Gladstone

Queensland 4680

Phone: +61 7 49784000

Facsimile: +61 7 49785685